

# CRB

## Horizontal Belt Conveyor (Troughed Roller Bed)

The Model CRB is ideally used in scrap handling and recycling operations. The roller bed with deep troughed construction can carry cullled or broken glass, cans, wood chips, aluminum, steel and plastic stampings. The CRB is widely used in recycling operations as an "Environmental Conveyor."

- 7 Bed Widths
- Side Mounted End Drive for Low Elevations
- Self-cleaning Tail Pulley
- Troughed Guard Rails
- Adjustable MS-Type Floor Supports Available

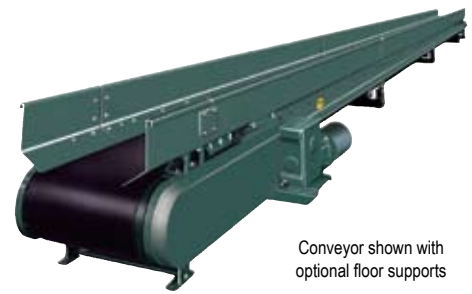

Conveyor shown with optional floor supports

SIZE TO ORDER Overall Length "A"	Bed Length "L"	WEIGHTS (Lbs.) Weights Based on 6" Roller Centers							
		Between Rail Width	9"	11"	13"	15"	17"	21"	27"
		Belt Width	12"	14"	16"	18"	20"	24"	30"
		Overall Frame Width	16"	18"	20"	22"	24"	28"	34"
		"W"	17 1/2"	19 1/2"	21 1/2"	23 1/2"	25 1/2"	29 1/2"	35 1/2"
		"B"	28 1/2"	30 1/2"	32 1/2"	34 1/2"	36 1/2"	40 1/2"	46 1/2"
7'	5'		410	425	440	460	480	520	570
12'	10'		525	550	570	605	635	685	765
17'	15'		675	705	735	780	825	885	990
22'	20'		790	830	865	920	975	1050	1180
27'	25'		945	990	1035	1105	1170	1260	1415
32'	30'		1055	1105	1155	1235	1315	1420	1600
42'	40'		1320	1385	1445	1550	1655	1785	2020
52'	50'		1585	1665	1740	1870	1995	2150	2440
62'	60'		1845	1940	2030	2185	2335	2520	2880
72'	70'		2110	2215	2320	2495	2670	2885	3280
82'	80'		2375	2495	2615	2815	3015	3255	3705
92'	90'		2645	2680	2715	3040	3365	3635	4135
102'	100'		2905	3050	3195	3445	3690	3985	4540

For 12" Centers Deduct Weights Listed Below															
Roller Centers	BR Width	5' Long Bed Sections							10' Long Bed Sections						
12"	Weight Deduction	9"	11"	13"	15"	17"	21"	27"	9"	11"	13"	15"	17"	21"	27"
		10	12	14	16	17	21	26	20	24	28	32	34	42	52

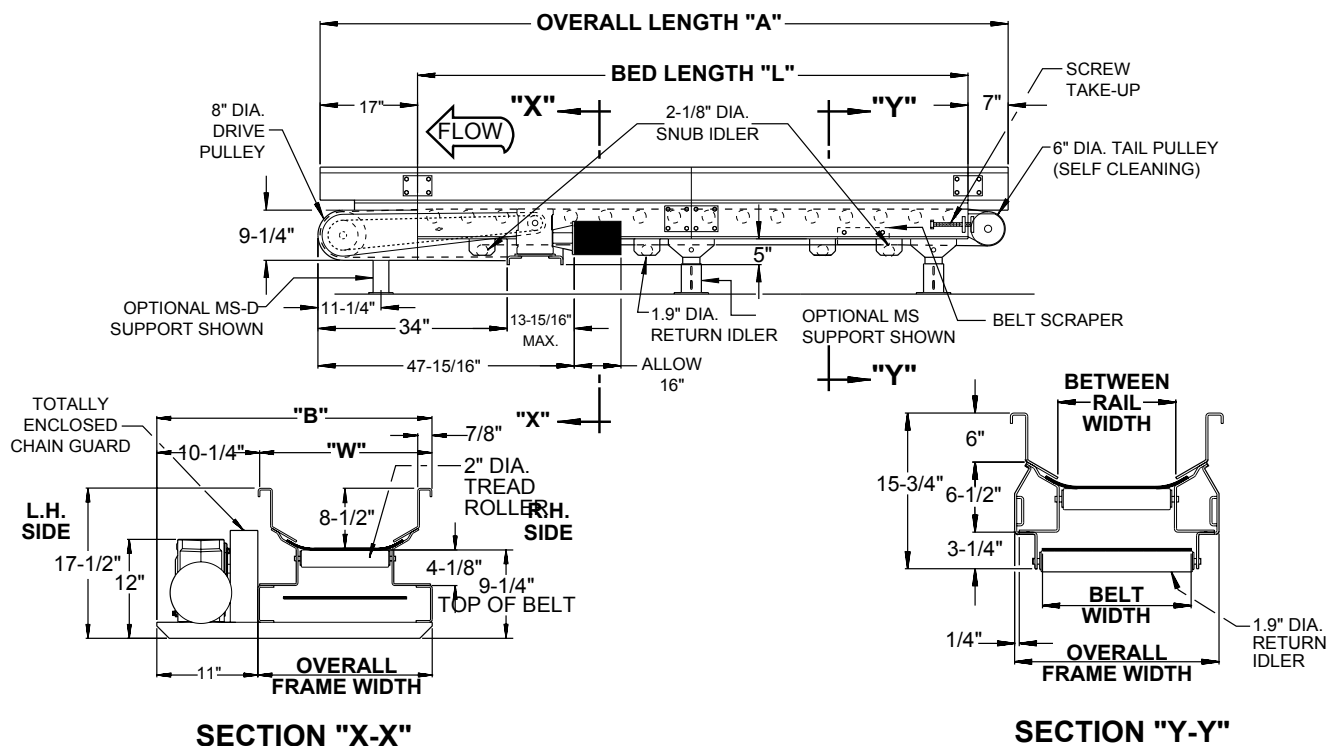

## • STANDARD SPECIFICATIONS

**BELT**—Black Trackmate 533 COS. Clipper lacing.

**BED**—Roller bed with 2 in. dia. x 12 ga. unplated tread rollers spaced every 6 in., or 12 in. mounted in 10 ga. painted formed steel channel frame with 12 ga. painted side guards extending 8 1/2" above belt. Sections bolt together with splice plates.

**END DRIVE**—Located on discharge end of conveyor, chain guard on left hand side.

**BELT SCRAPER**—Mounted in bed section to clean underside of return belt.

**DRIVE PULLEY**—8 in. dia. with 1 3/8 in. dia. shaft at bearings—machine crowned and fully lagged.

**TAIL PULLEY**—6 in. dia. with 1 3/8 in. dia. shaft at bearings—self-cleaning, crowned

**SNUB IDLER**—Adjustable—2 1/8 in. dia. Pre-lubricated ball bearings.

**RETURN IDLER**—Adjustable—1.9 in. dia. Pre-lubricated ball bearings.

**TAKE-UP**—Screw take-ups at tail pulley. Provides 4 in. of belt take-up.

**BEARINGS**—Sealed, pre-lubricated, self-aligning, cast-iron ball bearings on drive and tail pulley. Sealed, pre-lubricated ball bearings in tread rollers.

**SPEED REDUCTION**—Sealed worm gear "C" face speed reducer. No 50 roller chain to drive pulley.

**MOTOR**—1 HP—208/230/460/575V—3 Ph.—60 Hz.—Totally Enclose C-Face.

**BELT SPEED**—Constant 65 FPM.

**CAPACITY**—Maximum load per linear foot of conveyor—25 lbs. NOT TO EXCEED capacity in chart.

**FLOOR SUPPORTS**—Now supplied as optional equipment.

LOAD CAPACITY CHART		
HORIZONTAL CONVEYOR		
ROLLER BED @ 65 FPM		
HP	TOTAL LOAD (LBS.)	
	UP TO 52'	UP TO 102'
1	400	200
2	850	700



DETAIL VIEW OF SELF-CLEANING TAIL PULLEY

## • OPTIONAL EQUIPMENT

**FLOOR SUPPORTS**—MS Type floor supports are available with a wide range of adjustment. Specify top of belt or roller elevation. One support required at every bed joint and ends of conveyor. Holes in feet for lagging to floor. Knee braces recommended above MS-6 support.

**NOTE:** Drive end support non-adjustable up to 16 in. elevation.

**BELT SPEED**—Other constant and variable speeds. V-Belt drive supplied on speeds under 17 FPM.  
**Note:** Capacity affected with speed changes.

**CENTER DRIVE**—Provides 16 in. of belt take-up. Minimum elevation 20 in. Specify location. Minimum OAL 66 in.

**V-BELT DRIVE**—V-belt supplied between motor and reducer.

**O-RING DRIVE CHAIN**—With sealed in lubricant (Recommended for applications that do not permit regular lubrication).

**END CAP**—A formed steel end cap is bolted to inside of conveyor at tail end to keep material from falling off end of conveyor (not available with 7 in. extended guard rail.)

**CEILING HANGERS**—5/8 in. dia. x 8 ft. long unplated rods fully threaded. Other lengths and galvanized rods available.

**MOTORS**—Energy efficient—single phase, brakemotor—other characteristics. 2 HP maximum.

**ELECTRICAL CONTROLS**—Non-reversing magnetic starters and push-button stations. AC variable frequency drive.