

# GAPPER-L

## Horizontal Belt Gapping Conveyor With Controls (Slider Bed)

The model Gapper is designed for feeding sawtooth merges, combiners, sorters, or other equipment where gaps must be optimized between cartons or for feeding scales where carton pitch must be controlled.

- 5 Belt Widths
- High Grip Longitudinally Grooved Belt
- Pop-Out Roller
- Adjustable MS-Type Floor Supports Available
- 6 Speed Gap Ratios



Conveyor shown with optional floor supports



SIZE TO ORDER Overall Length	Belt Width	12"	18"	24"	30"	36"
	Between Rail Width	15"	21"	27"	33"	39"
	Overall Frame Width	18"	24"	30"	36"	42"
12'	Weights	905	1059	1208	1360	1512
Weight Per Foot		21	28	35	42	47

- NOTE:**
- 12'-0" OAL Minimum with 12", 18" & 24" Belts
  - 12'-6" OAL Minimum with 30" Belt
  - 15'-0" OAL Minimum with 36" Belt

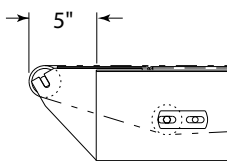
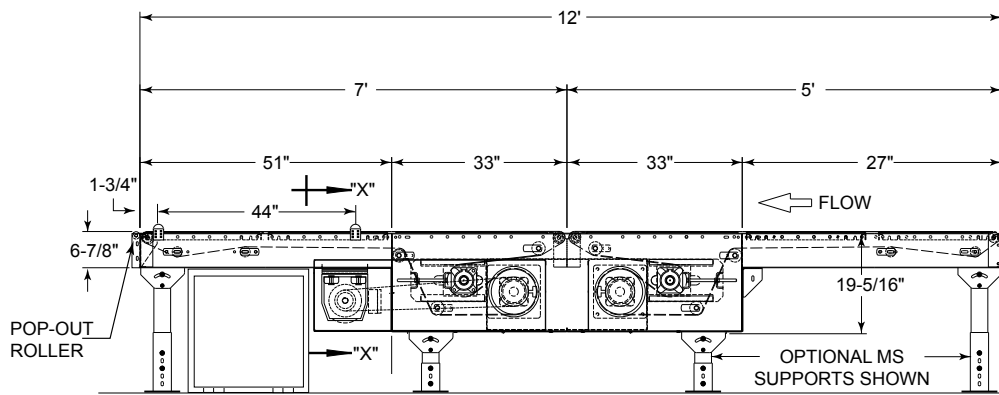

OPTIONAL ROUND END

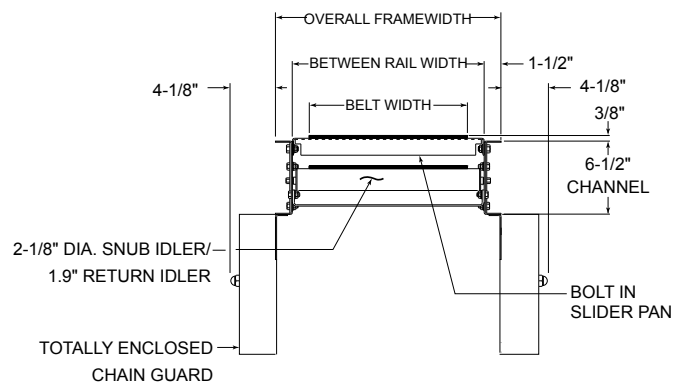

SECTION "X-X"

## • STANDARD SPECIFICATIONS

- BELT**—High grip longitudinally grooved belt; NSL10ELBV-UX-1-SP lacing.
- BED**—12 ga. galvanized slider pan mounted in 6 ½ in. x 12 ga. powder painted formed steel channel frame.
- CENTER DRIVE**—Provides 16 in. of belt take-up. Minimum elevation—20 in. Chain guard located on left hand side.
- DRIVE PULLEY**—8 in. dia. with 1 1/16 in. dia. shaft at bearings, machine crowned and fully lagged.
- TAIL PULLEY**—2 ¼ in. dia. with ¾ in. dia. shaft at bearings, machine crowned.
- POP OUT ROLLER**—1 3/8" with high speed bearing on discharge only.
- SNUB IDLER**—Adjustable 2 ½ in. dia. pre-lubricated ball bearings.

- BEARINGS**—Sealed, pre-lubricated, ball bearings on drive and tail shafts.
- TIMING BELT DRIVE**
- MOTOR**—5 HP Gearmotor with encoder. Requires 460 V 3 Ph. 60 Hz power supply to control panel.
- GAPLOGIX CONTROLS PACKAGE**—Electrical control package, 460 V 3 Ph. complete with electrical enclosure, disconnect, photo eyes, variable speed drive, machine interface and software for controlling speed in order to set gaps or pitch of cartons.
- Contact factory for other voltages.
- FLOOR SUPPORTS**—Now supplied as optional equipment.

Discharge Belt Speed	Conveyor OAW				
	18	24	30	36	42
	HP				
65 - 600	5	5	5	5	5

**NOTE:** Maximum operational speed will be limited to carton sizes being conveyed in order to prevent carton tumbling or sliding. Contact Factory for specific application limits.

$$\text{Infeed Belt Speed} = \frac{\text{Discharge Belt Speed}}{\text{SGR}}$$

**NOTE:** As cartons pass from the infeed belt to the higher speed discharge belt, a gap is created between cartons according to the following formula:

### FORMULA

$$\frac{\text{Length of Box} + \text{Final Gap}}{\text{Length of Box} + \text{Initial Gap}} = \text{Speed Gap Ratio (SGR)}$$

Gaps are then measured and speed altered during release of cartons to create desired final gap or pitch.

$$\text{SGR} = \frac{\text{Discharge Belt Speed}}{\text{Infeed Belt Speed}}$$

SGR
1.25
1.50
1.75
2.00
2.25
2.50

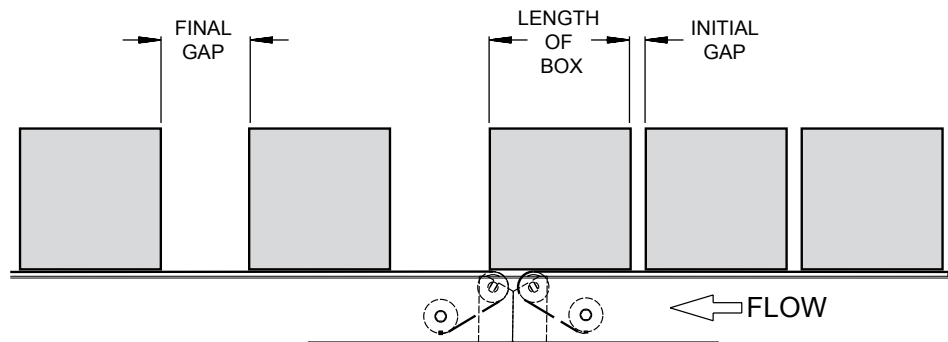

## • OPTIONAL EQUIPMENT

- FLOOR SUPPORTS**—MS Type floor supports are available with a wide range of adjustment. Specify top of belt or roller elevation. One support required at every bed joint and ends of conveyor. Holes in feet for lagging to floor. Knee braces recommended above MS-6 support.
- GUARD RAILS**—Adjustable Universal Channel Guard Rail, overlapping fixed channel (one direction).

- ROUND END**—For feeding combiners, or other equipment where the pulley needs to extend past the frame. Allow 5" extension.
- LENGTH**—Optional Lengths available in 3" increments. Minimum discharge 7', Minimum infeed 4', Maximum discharge 12'9", Maximum infeed 12'9".