

MODEL 800, 801 & 802 Wire Mesh Conveyors

This light to medium-duty wire mesh conveyor is designed to handle special applications with a variety of deck options including rollers, longitudinal wear strips and herringbone wear strips.

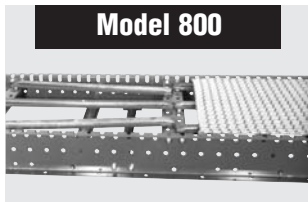

Model 800

Model 800

Herringbone Wear Strip Deck:

- The Herringbone wear strips are made of stainless steel
- Ideal for water, high temperature and/or dirty and gritty applications
- The unique Herringbone deck pattern spreads the belt wear evenly across the belt

Model 800

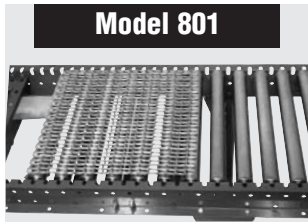
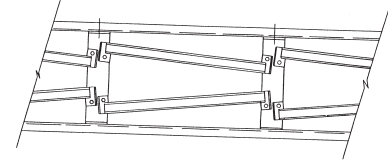

Model 801

Model 801

Roller Bed Deck:

- Medium- to heavy-duty applications
- Rollers reduce friction between the wire mesh and deck optimizing drive horsepower

Model 801

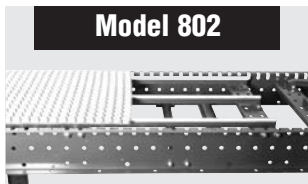
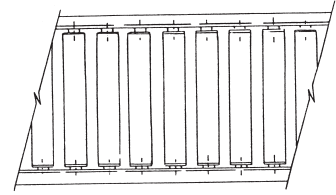

Model 802

Model 802

High-density Plastic Wear Strip Deck:

- An all-around cost-effective performer
- Light- to medium-duty applications
- "Snap on, Snap off" wear strips are easy to replace

Model 802

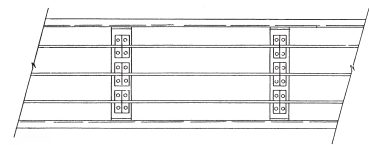

| | | | | | |
|---------------------|---------|---------|---------|---------|---------|
| Belt Width: | 12" | 18" | 24" | 30" | 36" |
| Frame Width: | 15-1/2" | 21-1/2" | 27-1/2" | 33-1/2" | 39-1/2" |

Wire mesh conveyors are designed to carry hot or cold items from ovens or freezers. They are also used when items need to be washed or dried.

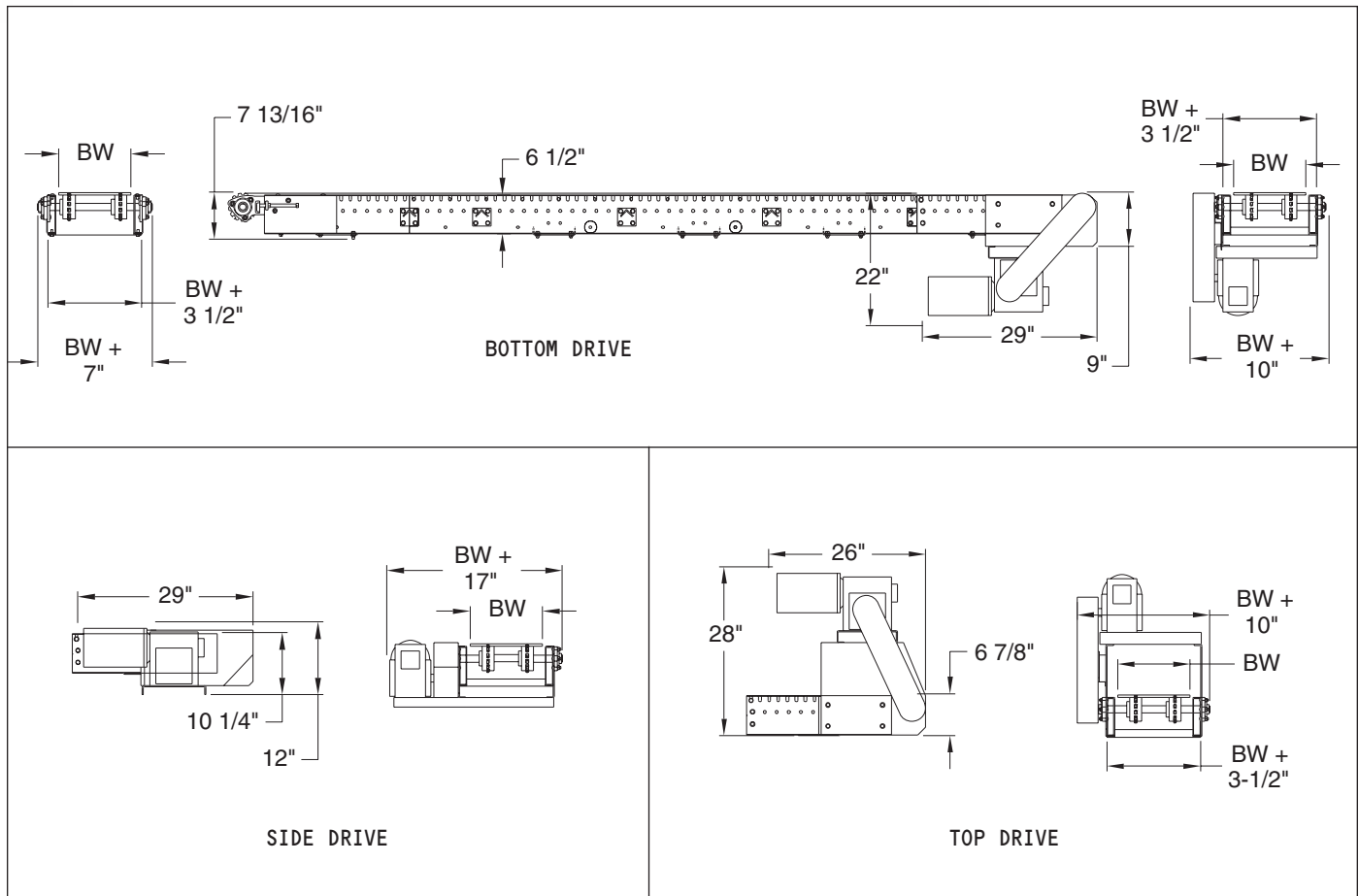

MODEL 800, 801 & 802 Wire Mesh Conveyors

Standard Specifications

Widths: 12" – 36" (Custom Widths Available)

Standard Speed: 60 FPM

Standard Motor: 1/2 HP 230/460/3/60 TEFC

Standard Drive: Bottom Mount @ Discharge

Frame: 12 Gauge x 6-1/2" Deep

Bearings: Grease Sealed

Sprockets: 13 Tooth x 4.1" Pitch Diameter

Standard Mesh: 1/2" x 1" Galvanized Steel

Wire Mesh Conveyors Comparison Chart

Wire Mesh Conveyors — Wire mesh conveyors are designed to carry hot or cold items from ovens or freezers. They are also used when items need to be washed and/or dried.

| MODEL | DESCRIPTION (BED STYLE) | FRAME GAUGE | FRAME DEPTH | DRIVER SIZE | *DRIVER TYPE* | DRIVE SHAFT DIA. | IDLER SIZE | IDLER TYPE | IDLER SHAFT DIA. | STANDARD CARRIER | STD. DRIVE | OTHER |
|-------|-------------------------|-------------|-------------|-------------|---------------|------------------|------------|------------|------------------|-------------------------------------|--------------|------------------------------------|
| 800 | Herringbone style bed | 12 | 6.5" | 13 tooth | 4.1" pd | 1.1875" | 13 tooth | 4.1 pd | 1.1875" | 1/2" x 1" galvanized flat wire mesh | Bottom mount | Used for product washing or drying |
| 801 | Roller bed | | | | | | | | | | | |
| 802 | UHMW wear strip bed | | | | | | | | | | | |

Unit Weights (Shipping Weights – lbs.)

Model 800

| BELT WIDTH | 12" | 18" | 24" | 30" | 36" |
|----------------|------|------|------|------|------|
| LENGTHS | | | | | |
| 5' | 340 | 385 | 430 | 475 | 520 |
| 10' | 443 | 519 | 595 | 671 | 747 |
| 15' | 581 | 689 | 797 | 905 | 1013 |
| 20' | 684 | 823 | 962 | 1101 | 1240 |
| 25' | 822 | 993 | 1164 | 1335 | 1506 |
| 30' | 925 | 1127 | 1329 | 1531 | 1733 |
| 35' | 1063 | 1297 | 1531 | 1765 | 1999 |

Conveyor weights include supports.
Other options, crating etc. are not included.

Model 801

| BELT WIDTH | 12" | 18" | 24" | 30" | 36" |
|----------------|------|------|------|------|------|
| LENGTHS | | | | | |
| 5' | 331 | 374 | 417 | 460 | 503 |
| 10' | 426 | 496 | 566 | 636 | 706 |
| 15' | 556 | 654 | 752 | 850 | 948 |
| 20' | 651 | 776 | 901 | 1026 | 1151 |
| 25' | 781 | 934 | 1087 | 1240 | 1393 |
| 30' | 876 | 1056 | 1236 | 1416 | 1596 |
| 35' | 1006 | 1214 | 1422 | 1630 | 1838 |

Conveyor weights include supports.
Other options, crating etc. are not included.

Model 802

| BELT WIDTH | 12" | 18" | 24" | 30" | 36" |
|----------------|------|------|------|------|------|
| LENGTHS | | | | | |
| 5' | 321 | 364 | 409 | 454 | 499 |
| 10' | 424 | 498 | 574 | 650 | 726 |
| 15' | 562 | 668 | 776 | 884 | 992 |
| 20' | 665 | 802 | 941 | 1080 | 1219 |
| 25' | 803 | 972 | 1143 | 1314 | 1485 |
| 30' | 906 | 1106 | 1308 | 1510 | 1712 |
| 35' | 1044 | 1276 | 1510 | 1744 | 1978 |

Conveyor weights include supports.
Other options, crating etc. are not included.

Skid Dimensions

CONTACT NLE FOR SKID DIMENSIONS



Quality Conveyors Since 1948

1700 Division Street • New London, WI 54961

800-437-1994 • 920-982-4030 • fax: 920-982-6800 • www.nleco.com