

190-NSPC

The 190 Spool Curves and Spurs are designed to be slave driven from the 190-NSP Conveyor. Curves are used where turns in the conveyor line are necessary. Spurs are used in diverging and converging applications.

- 12 Bed Widths
- Slave Driven from Model 190-NSP
- Adjustable MS-Type Floor Supports Available

Between Rail Width	Overall Frame Width	"R"	Total Number of Rollers*				WEIGHTS (Lbs.)			
			90°	60°	45°	30°	90°	60°	45°	30°
13"	16"	24"	16T/4S	10T/4S	8T/12S	5T/12S	179	144	157	132
15"	18"						222	184	183	151
17"	20"						235	197	192	158
19"	22"						248	209	202	165
21"	24"						259	224	211	173
23"	26"						281	233	222	181
25"	28"	32 1/2"	20T/4S	12T/4S	10T/12S	6T/12S	285	246	231	189
27"	30"						299	258	241	199
31"	34"						437	338	313	247
33"	36"						452	353	326	259
37"	40"						484	380	349	271
39"	42"						503	395	361	285
		48"	28T/4S	20T/4S	14T/12S	10T/12S	503	395	361	285

*T = TAPERED S = STRAIGHT

All weights in catalog are conveyor weights only. Accessories, crating, etc., are not included.

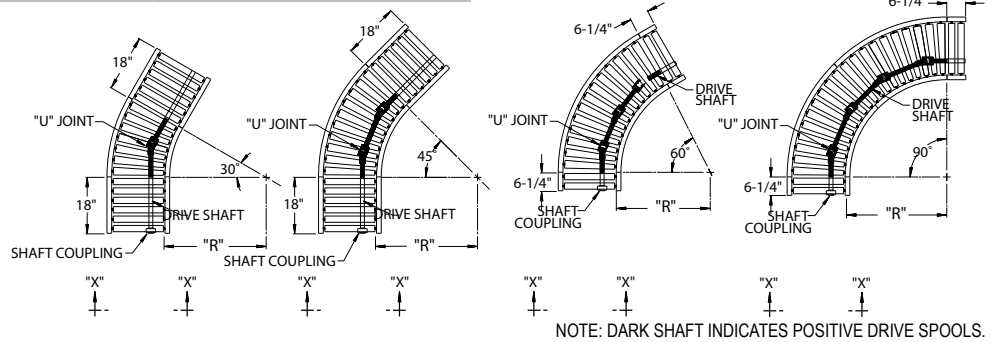
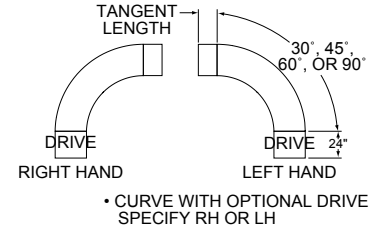

190-NSPS

Between Rail Width	Overall Frame Width	"R"	"A"		"B"		"C"		"D"		"E"		Number of Rollers*		WEIGHTS (Lbs.)		
			45°	30°	45°	30°	45°	30°	45°	30°	45°	30°	45°	30°	45°	30°	
13"	16"	24"	29"	38"	27"	36"	21"	30"	21 7/8"	38"	50"	42 1/4"	8T/12S	10T/11S	173	176	
15"	18"		32"	41"	30"	39"										230	263
17"	20"		35"	47"	33"	45"										240	274
19"	22"		38"	50"	36"	48"										250	283
21"	24"		32 1/2"	41"	53"	39"	51"	36"	54"	35"	63"	66 5/8"	61 3/8"	10T/17S	12T/19S	259	293
23"	26"			44"	56"	42"	54"									268	303
25"	28"	47"		62"	45"	60"	280									316	
27"	30"	50"		65"	48"	63"	288									325	
31"	34"	56"		74"	54"	72"	410									499	
33"	36"	59"		77"	57"	75"	422									513	
37"	40"	48"	65"	86"	63"	84"	48"	75"	48"	89"	86"	85 1/2"	14T/21S	20T/26S	446	540	
39"	42"		68"	89"	66"	87"									457	553	

*T = TAPERED S = STRAIGHT

All weights in catalog are conveyor weights only. Accessories, crating, etc., are not included.

